

IP EYE-SIGHT SERIES

The new Eye-Sight series serves the security professionals seeking a professional line featuring outstanding image quality, full connectivity, and enhanced video analytics functions based on **Artificial Intelligence**.



DI-340IPEN-MVF

40M IR 4MP DDA ANALYTICS MOTORIZED LENS DOME/TURRET CAMERA

Equipped with a 2.8-12mm motorized lens, this 4MP Dome/Turret camera is designed for medium distance surveillance (up to 40m) in indoor and outdoor scenarios. The camera offers broad possibilities for Analytics, from Face Detection to the outstanding DDA Analytics (Detect, Distinguish, Alert), which can perform object recognition and object counting. With various detection rules and triggers, the DI-340IPEN-MVF camera will help end false alarms.



DDA
VIDEO ANALYTICS



NDAA
Compliance

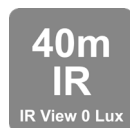

MAIN FEATURES

- 4MP
- EYE-SIGHT V2
- 2592×1520 Resolution
- 2.8-12mm Motorized Vari-Focal (96°- 32°)
- 3D-DNR
- IP67
- DDA Analytics
- Audio in + Built-in microphone

ANALYTICS

- General Analytics: Camera Tampering
- AI (Object Recognition): Humans, 2/4 wheel vehicles
DDA Sterile Area
DDA Line Crossing
DDA Object Counting
- AI (Face Detection): 10 Faces per frame



SPECIFICATIONS

Image Sensor	1/3" CMOS (16:9)
Effective Pixels	2592X1520
Electronic Shutter	1/25s ~ 1/100000s
Frame Rate	1-25/30FPS in Normal Mode. 1-50/60FPS in HFR Mode***
Day & Night	ICR
Min. Illumination	Day: 0.1lux / Night: 0.005lux (@F1.6, AGC on) 0lux with IR on
Audio compression	G.711A/G.711U
Communication	One-way Audio
Image Settings	AWB, AGC Adjustable, Exposure Mode (Auto) Sharpness, Saturation, Brightness & Contrast Adjustable
Image Enhancement	True WDR (120dB), BLC, HLC, ROI
Noise Reduction	3D-DNR
Image Orientation	Mirror/Flip
Privacy Zone	Yes
Motion Detection	Yes
Analytics	Object Detection (Sterile Area, Line Crossing, Object Counting), Face Detection (10 Faces per frame), Camera Tampering
Video Compression	H.265S/H.264S*, H.265+/H.264+/H.265/H.264/MJPEG
Resolution	4MP / 2K / 3MP / 2MP / 1MP / D1 / QVGA / CIF
Multi-Stream	Master Stream: 4MP(2592x1520) / 2K (2560x1440) / 3MP / 2MP / 1MP Substream: 1MP/QVGA/D1/CIF Third Stream: QVGA/D1/CIF (1~30fps)
Bit rate	64Kbps ~ 7Mbps@H.265 / 64Kbps ~ 8Mbps@H.264
Encode Mode	VBR/CBR
Image Quality	Five levels under VBR; Free adjustment under CBR
IR Distance	40m (3 High Power IR LED)
Lens (Field of View)	2.8-12mm MVF with Auto Focus (94.3°- 29.9°)

*Main Stream Only, ***1080p,no true-WDR

SPECIFICATIONS

Iris	DC Iris
Lens Mount	Ø14 Mount
Protection Rate	Water Proof: IP67
Bracket	3-Axis Bracket
Dimensions	Ø113mm×99.6mm
Weight (gross)	~640g
Network	RJ45 (+PoE)
Power	DC Socket
Analog Video Output	No
Audio Connectivity	Built-in Microphone + Audio Input
SD Card	Event/Schedule based Main/Substream recording (Up to 128Gb)
Hard Reset Button	Yes
Alarm	No
Remote Monitoring	IE Browsing, VMS Software, Provision Cam2 Mobile App
User Access	Supports simultaneous monitoring of up to 10 users with multi-stream real-time transmission
Network Protocol	IPv4, IPv6, TCP, UDP, DHCP, NTP, DDNS, 802.1X, RTSP, Multicast, UPnP, Email, FTP, HTTPS, QoS, P2P
ONVIF	Yes
Ethernet	100Mbps
PoE	Yes
Power Supply	DC12V/~900mA / PoE/~10W
Work Environment	-30°C~60°C, 10%~90% Humidity
Junction Box	PR-JB14IP66 - PR-JB14IP64 - PR-WB-A

DIMENSIONS

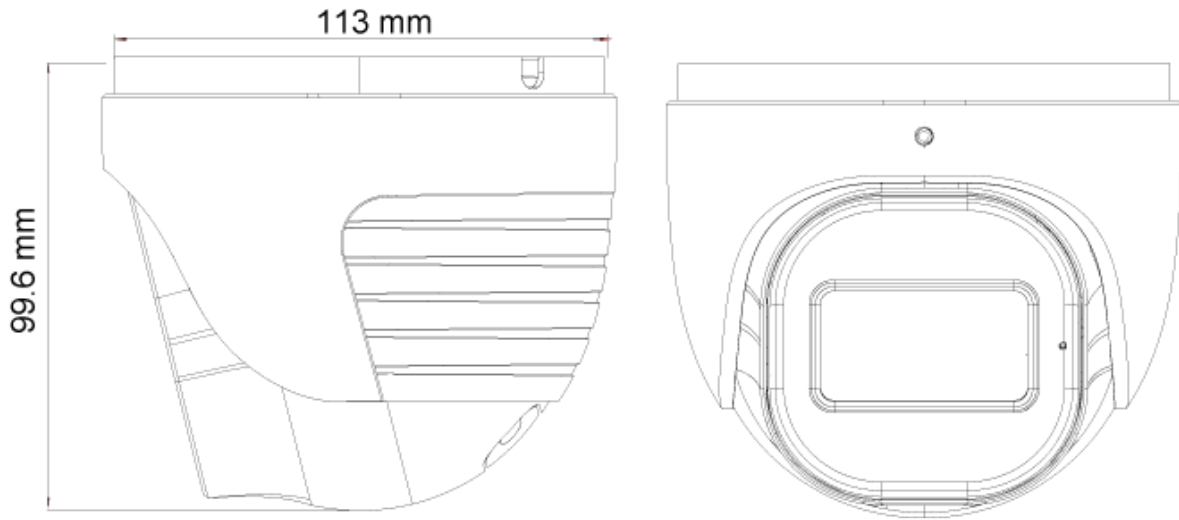

ACCESSORIES



PR-JB14IP66

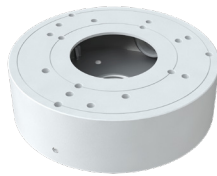

PR-JB14IP64



PR-WB-A